

## Quick Reference Guide Flexstrip Jumpers

Flexstrip jumpers provide a secure and reliable multi-conductor board-to-board connection. As an alternative to conventional point-to-point wiring, TE's Flexstrip jumpers offer a flat conductor construction that provides unrivalled flexibility and resistance against vibration and high flexing cycles. Especially in applications that require a reliable high performance interconnect, the Flexstrip jumpers can be repeatedly flexed without failure. Available in a wide range of board-to-board jumpers to suit all standard PCBs, this solution does not require any crimping or cutting and so ensures an easy assembly and soldering process, as well as low installation costs.

### FEATURES AND BENEFITS

- Versatile and highly flexible board to board jumper system
- Provides connections between PCBs, within a piece of equipment without wire stripping or preparation
- Lowest installed cost because no crimping or cutting is required
- Four insulation materials for high commercial, automotive as well as military/aerospace applications (Nomex, Teflon, Polyester and Kapton)
- Nine conductor pitches
- Various lengths from 0.5 to 30 Inches in .100" increments
- Various pin lengths to suit all standard PCBs
- One piece copper construction with round copper conductors rolled flat for high flex life, tin-plated for easy soldering
- Round-to-flat design provides vibration resistant reliability and life

### PRODUCT APPLICATIONS

- Computers
- Handheld Terminals
- Bar Code Readers
- Printers
- Consumer Devices
- Automotive
- Industrial Machinery
- Household Appliances



# How to create your own Flexstrip Jumper?

## Step 1. Choose isolation material

Insulation Material	Polyester	NOMEX®	TEFLON®	KAPTON®
Description	Improved electrical and mechanical properties when compared to Nomex for more demanding general purpose applications.	Low cost paper based material. Ideal for general purpose applications in normal environments where a change in resistance due to humidity is not critical.	Superior electrical and mechanical properties. Particularly suitable for applications where there is moisture or changing climatic conditions.	Unsurpassed mechanical properties especially at very high temperatures. Widely used for military and aerospace applications and critical areas of vehicles.

Table 1. Description of isolation material

Insulation Material	Polyester	NOMEX®	TEFLON®	KAPTON®
Conductor Pitch	9 different Pitches (see Step 2. Create an Smart Description code. A. Pitch)			
Flammability Rating	V0	V0	V0	V0
Equivalent Conductor Size (American Wire Gauge)	24	24	24	24
Insulation Resistance (gnd, sig, gnd) 12 inch. Sample @ 500 VDC	1x10 <sup>9</sup> Ω	1x10 <sup>9</sup> Ω	1x10 <sup>9</sup> Ω	1x10 <sup>9</sup> Ω
Capacitance (picofarad/foot) (gnd, sig, gnd)	11.1 pF/ft	11.2 pF/ft	11.4 pF/ft	10.4 pF/ft
Characteristic Impedance Ω (gnd, sig, gnd)	115 Ω	117 Ω	114 Ω	119 Ω
Temperature Rating	-40 °C - 105 °C	-40 °C - 125 °C	-40 °C - 150 °C	-40 °C - 150 °C
Current Rating	3 amps	3 amps	3 amps	3 amps
Voltage Rating	300 VAC	300 VAC	300 VAC	300 VAC
Min. Breakdown Voltage @ 1 min	1500 VAC	1500 VAC	1500 VAC	1500 VAC
Min. Bend Radius (in inch)	1/8"	1/8"	1/8"	1/8"

No ozone depleting substances are used in the production processes for Flexstrip Jumpers. Table 2. Specifications of isolation materials (based on .100" pitch Jumper).

**Step 2. Create a Smart Description Code**

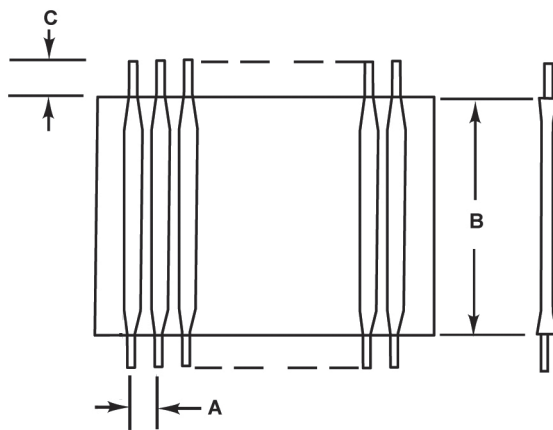
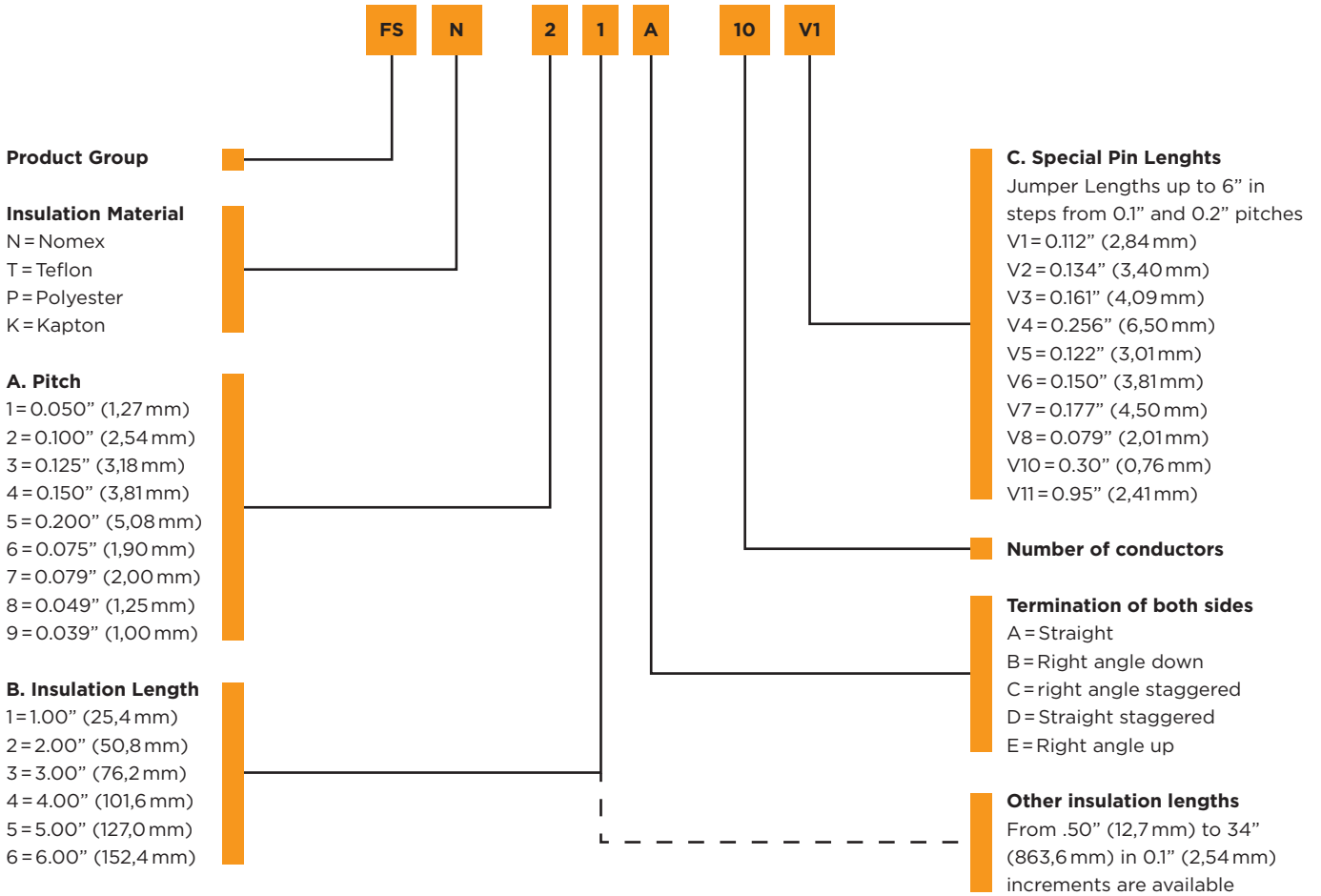

Figure 1. Flexstrip Jumper

**The following promotional material is available for your use**

- Quick reference guide: 4-1773700-3
- Product specifications: 108-2135
- Generic customer drawing: 1474339
- Sample box: 2142684-1

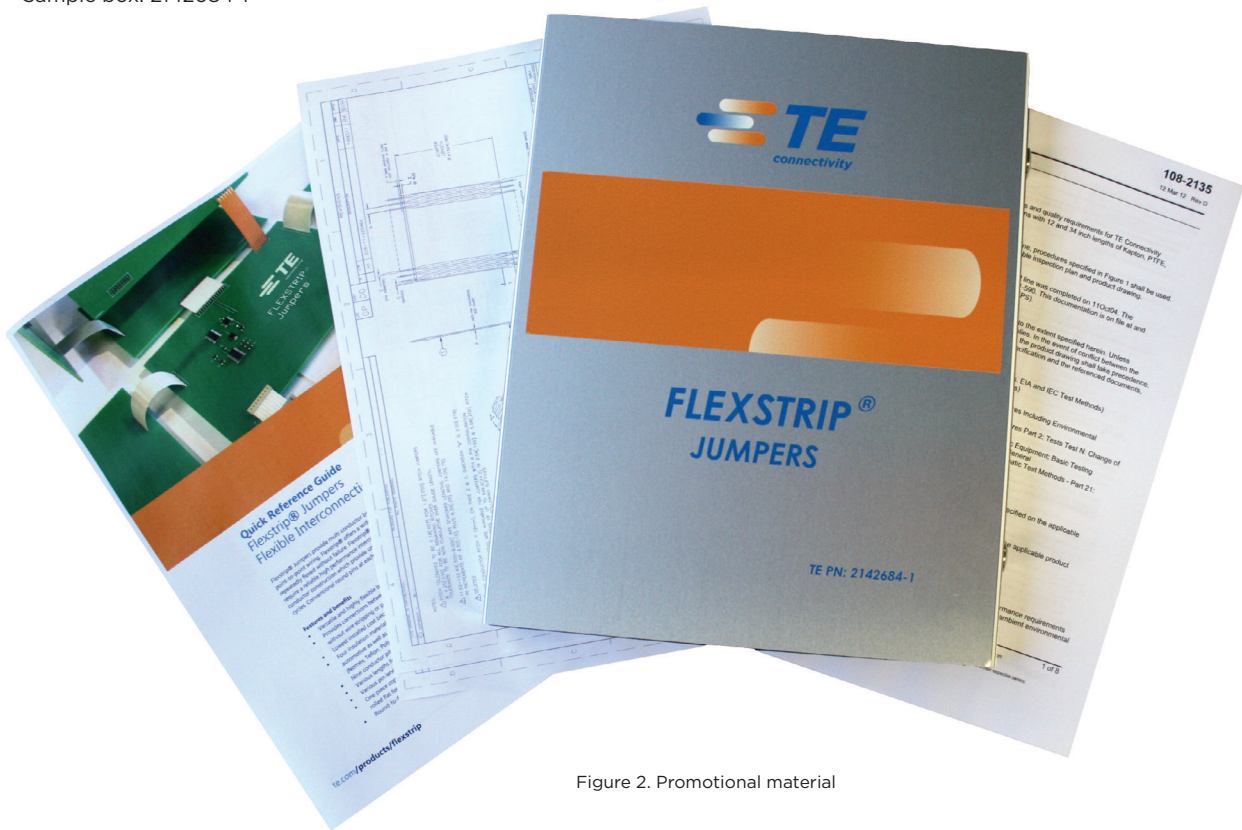

Figure 2. Promotional material

## Benefits of Flexstrip Jumper?

Key to the performance benefit of Flexstrip Jumpers is the flat conductors construction achieved by a special manufacturing process. Round conductors rolled flat provide unrivalled flexibility and resistance against vibration and high flexing cycles. Conventional round pins at each end ensure simplified assembly and soldering.

The smooth notchless transition from the flat conductor to the round contact pin guarantees a termination area that is break-proof and free of stress.

With strong vibrations, frequencies occur that can lead to resonance in the structure of equipment and the printed circuit board. For this reason, a high degree of stress often occurs at the termination points in particular, which are typically the weakest links in the system. Such stresses are frequently the cause of wire fracture in the contact area leading to costly equipment failures.

With their flat conductor construction, Flexstrip jumpers perform reliably in vibration situations due to their special flat to round transition zone that transfers the stress uniformly across the entire length of the jumpers. In addition, Flexstrip jumpers act as a vibration absorber ensuring that any vibration is quickly dissipated and not transferred to other areas of the equipment where additional problems may occur.

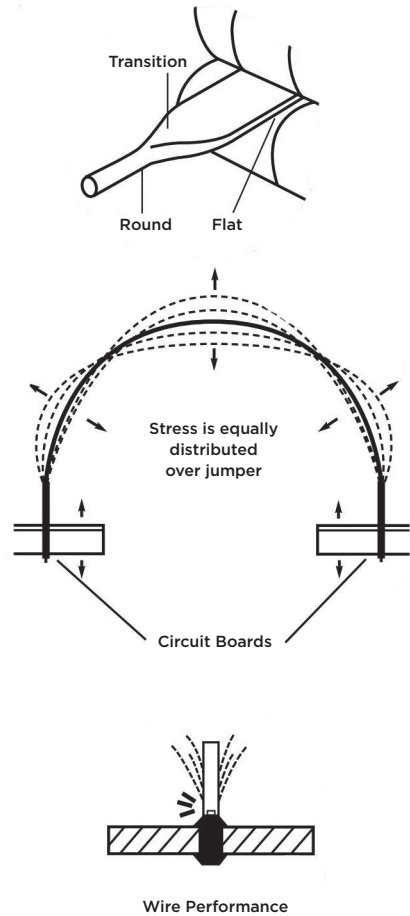

Figure 2. Benefits of Flexstrip jumpers

## Frequently asked questions

### How can I get samples of Flexstrip Jumpers?

Flexstrip Jumpers are made to order parts, therefore no sample stock.  
Please contact TE Product Management at G.Doremalen@te.com for sample requests.

### Where can I receive pricing information?

Please contact TE Product Management at G.Doremalen@te.com and we will provide pricing information for your special request.

### Once I have generated the Smart Description code, where can I order the Flexstrip Jumpers?

Please contact our TE Product Management at G.Doremalen@te.com or our Technical Support Centers.

### What is the shortest jumper length TE can produce?

Shortest length is .50"/12,7 mm

## FOR MORE INFORMATION

### TE Technical Support Center

USA:	+1 (800) 522-6752
Canada:	+1 (905) 475-6222
Mexico:	+52 (0) 55-1106-0800
Latin/S. America:	+54 (0) 11-4733-2200
Germany:	+49 (0) 6251-133-1999
UK:	+44 (0) 800-267666
France:	+33 (0) 1-3420-8686
Netherlands:	+31 (0) 73-6246-999
China:	+86 (0) 400-820-6015

Part numbers in this brochure are RoHS Compliant\*, unless marked otherwise.

\*as defined [www.te.com/leadfree](http://www.te.com/leadfree)

## te.com

© 2013 Tyco Electronics Corporation, a TE Connectivity Ltd. Company. All Rights Reserved.

4-1773700-3 CIS WR 06/2013

NOMEX, KAPTON, TEFLON, TE Connectivity and TE connectivity (logo) are trademarks.

Other logos, product and/or company names might be trademarks of their respective owners.

While TE has made every reasonable effort to ensure the accuracy of the information in this document, TE does not guarantee that it is error-free, nor does TE make any other representation, warranty or guarantee that the information is accurate, correct, reliable or current. TE reserves the right to make any adjustments to the information contained herein at any time without notice. TE expressly disclaims all implied warranties regarding the information contained herein, including, but not limited to, any implied warranties of merchantability or fitness for a particular purpose. The dimensions in this document are for reference purposes only and are subject to change without notice. Specifications are subject to change without notice. Consult TE for the latest dimensions and design specifications.

